

CONFIGURAZIONE / CONFIGURATION / KONFIGURATION

Descrizione meccanismo	Mechanism description	Getriebebeschreibung	RIG09 2-330 VRA VCS DA
Legge di moto	Motion law	Bewegungsgesetz	2-330 (Ca=5.528)
N° cicli	Number of cycles	Anzahl der Schaltzyklen	1
Versione uscita	Output version	Ausführung Schalttisch	VCS
Piano albero entrata	Input shaft projection	Seite mit Antriebswelle	DA
Predisposizione riduttore	Gearbox pre-arrangement	Einrichtung für Getriebe	70/F3
Posizione riduttore	Gearbox position	Anbaulage des Getriebes	S3
Forature sul piano superiore della scatola	Holes on the housing upper plane	Gewindebohrungen in der Gehäuseoberseite	No
Forature opzionali di riferimento	Optional reference holes	Optionale Stiftlochbohrungen	No

RIDUTTORE / GEAR UNIT / GETRIEBE

Descrizione riduttore	Gear unit description	Getriebebezeichnung	CBF 70/F3
Predisposizione motore	Preset for IEC motor	Verbindungen mit IEC-Motor	71B5
Rapporto riduzione	Gearbox reduction ratio	Getriebeübersetzung	1:130
Taratura	Adjustment	Auslösemoment	-
Codice riduttore	Gear unit code	Getriebe-code	3116674

MOTORE / MOTOR / MOTOR

Descrizione motore	Motor description	Motorenbeschreibung	BA71C4B5
Freno	Brake	Bremse	Yes
Tensione e Frequenza	Voltage and Frequency	Spannung und Frequenz	230/400V 50Hz - 277/480V 60Hz
Potenza	Power	Leistung	0.55 kW
Codice motore	Motor code	Motor Code	3104079

MICRO / MICRO / ENDSCHALTER

Tipo gruppo micro	Micro assembly type	Typ der Endschalterbaugruppe	MID
Versione micro	Micro version	Version der Endschalterbaugruppe	Full

A

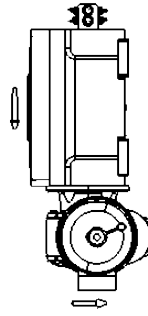

B

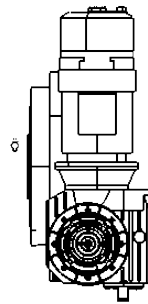

C

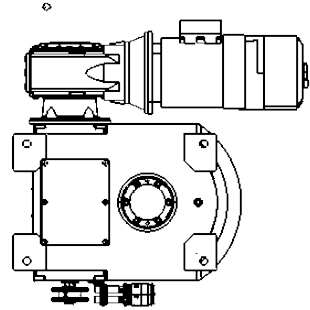
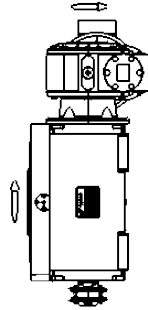

D

E

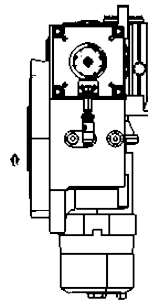

F PC5005243

	Date	Name
Draw	18/05/2026	L. C.
	Scale	Sheet
	1:15	1/1



COLOMBO FILIPPETTI SPA
 I-24040 Casirate d'Adda
 www.cofil.com
 PROPERTY RESERVED

Code	PC5202066
Description	RIG09 2-330 VRA VCS DA 70/F3

Le dimensioni del singolo meccanismo RIG, corrispondono all'ultima versione del catalogo disponibile sul sito www.cofil.it
 The dimensions of the single RIG mechanism, correspond to the latest version of the catalogue available on the website www.cofil.com
 Die Abmessungen des einzelnen RIG-Mechanismus, entsprechen der neuesten Version des Katalogs der auf der Website www.cofil.com verfügbar ist