

### CONFIGURAZIONE / CONFIGURATION / KONFIGURATION

Descrizione meccanismo	Mechanism description	Getriebebeschreibung	RIG06 32-310 VLRAx VCT DA
Legge di moto	Motion law	Bewegungsgesetz	32-310 (Ca=5.528) -
N° cicli	Number of cycles	Anzahl der Schaltzyklen	4
Versione uscita	Output version	Ausführung Schalttisch	VCT
Piano albero entrata	Input shaft projection	Seite mit Antriebswelle	DA
Predisposizione riduttore	Gearbox pre-arrangement	Einrichtung für Getriebe	50/F1 LCB
Posizione riduttore	Gearbox position	Anbaulage des Getriebes	S1
Forature sul piano superiore della scatola	Holes on the housing upper plane	Gewindebohrungen in der Gehäuseoberseite	No
Forature opzionali di riferimento	Optional reference holes	Optionale Stiftlochbohrungen	Yes

### RIDUTTORE / GEAR UNIT / GETRIEBE

Descrizione riduttore	Gear unit description	Getriebebezeichnung	CBF 50/F1 LCB
Predisposizione motore	Preset for IEC motor	Verbindungen mit IEC-Motor	63B5
Rapporto riduzione	Gearbox reduction ratio	Getriebeübersetzung	1:113.9
Taratura	Adjustment	Auslösemoment	26.6 Nm
Codice riduttore	Gear unit code	Getriebe-code	3107344

### MOTORE / MOTOR / MOTOR

Descrizione motore	Motor description	Motorenbeschreibung	BM63C4B5
Freno	Brake	Bremse	Yes
Tensione e Frequenza	Voltage and Frequency	Spannung und Frequenz	230/400V 50Hz - 277/480V 60Hz
Potenza	Power	Leistung	0.22 kW
Codice motore	Motor code	Motor Code	3123225

### MICRO / MICRO / ENDSCHALTER

Tipo gruppo micro	Micro assembly type	Typ der Endschalterbaugruppe	CM (singolo)
Versione micro	Micro version	Version der Endschalterbaugruppe	Full

A

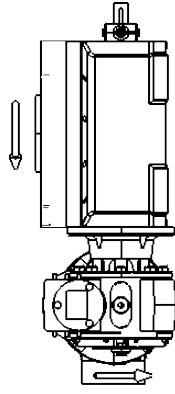

B

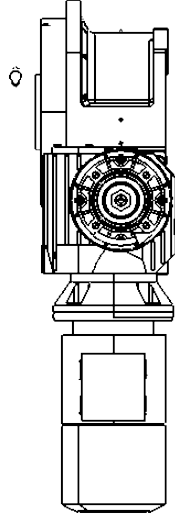

C

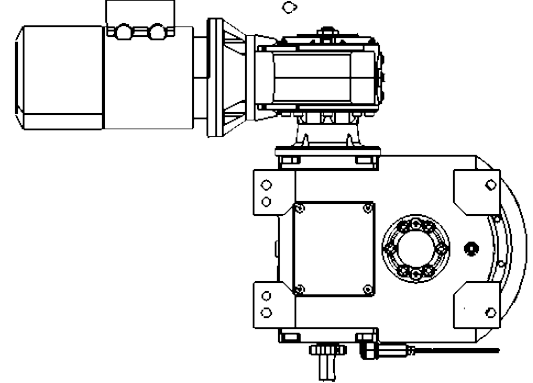
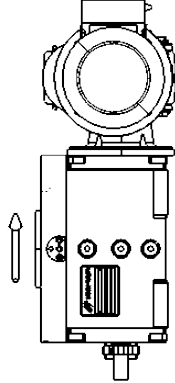
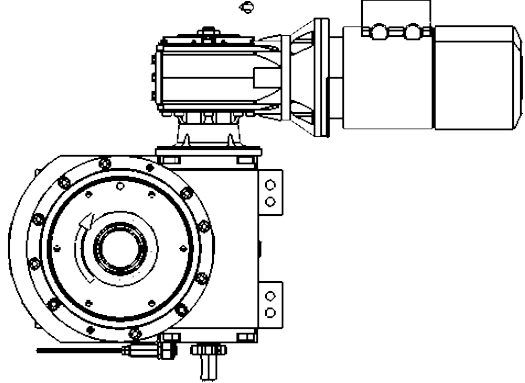

D

F

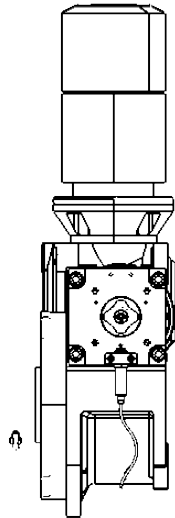

PC5002744

Le dimensioni del singolo meccanismo RIG, corrispondono all'ultima versione del catalogo disponibile sul sito [www.cofil.it](http://www.cofil.it)  
 The dimensions of the single RIG mechanism, correspond to the latest version of the catalogue available on the website [www.cofil.com](http://www.cofil.com)  
 Die Abmessungen des einzelnen RIG-Mechanismus, entsprechen der neuesten Version des Katalogs der auf der Website [www.cofil.com](http://www.cofil.com) verfügbar ist

	Date	Name
Draw	12/03/2026	L. C.
	Scale	Sheet
	1:9	1/1



**COLOMBO FILIPPETTI SPA**  
 I-24040 Casirate d'Adda  
[www.cofil.com](http://www.cofil.com)  
 PROPERTY RESERVED

Code	<b>PC5201922</b>
Description	RIG06 32-310 VLRAX VCT DA F 50/F1 LCB